

Visio 40 wewnętrzny z belką

100 kg

MONTAŻ DO
GOTOWEJ PODŁOGI
MOUNTING ON FINISHED
FLOOR LEVEL

40 mm
PŁYTA | BOARD

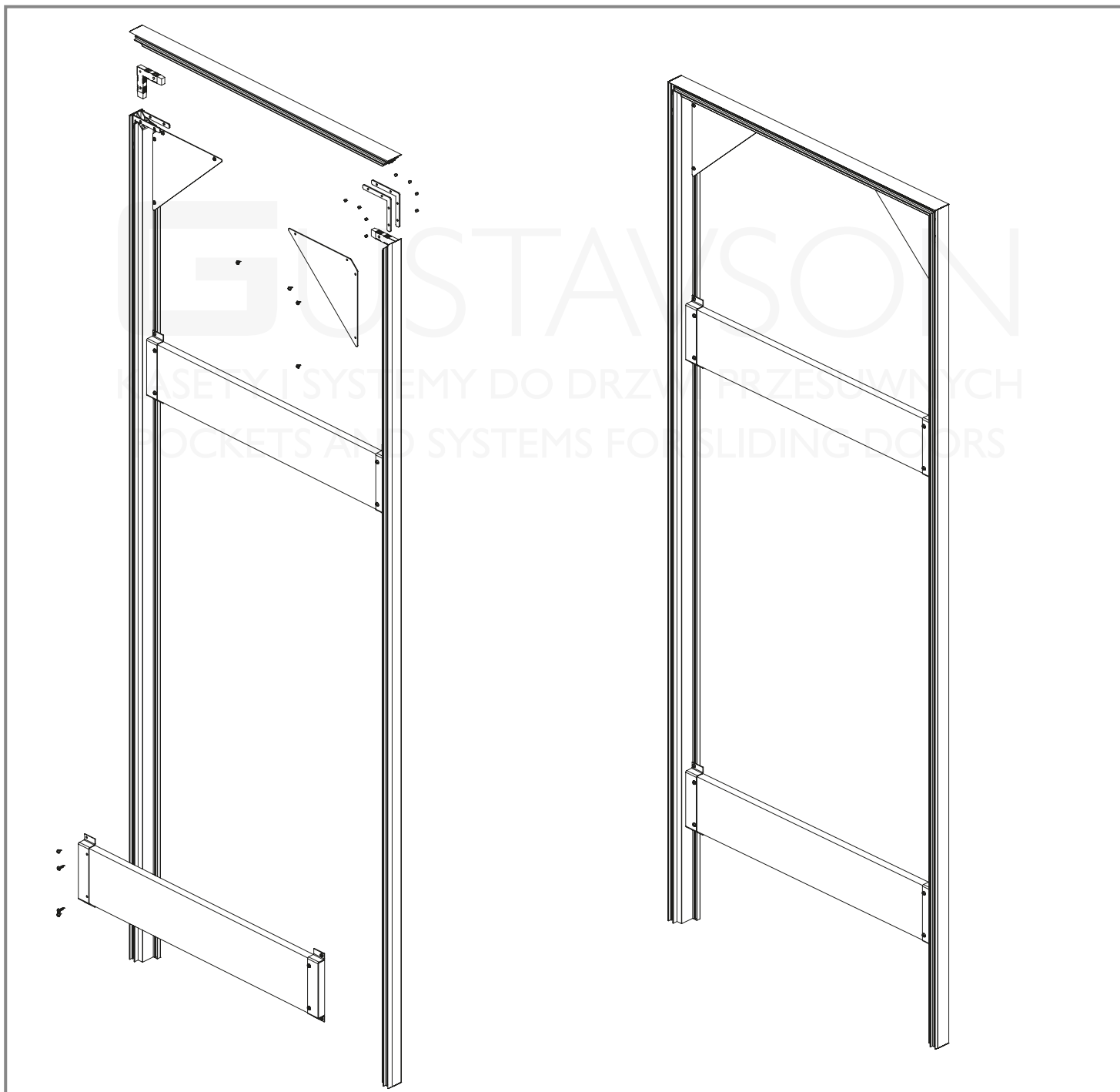
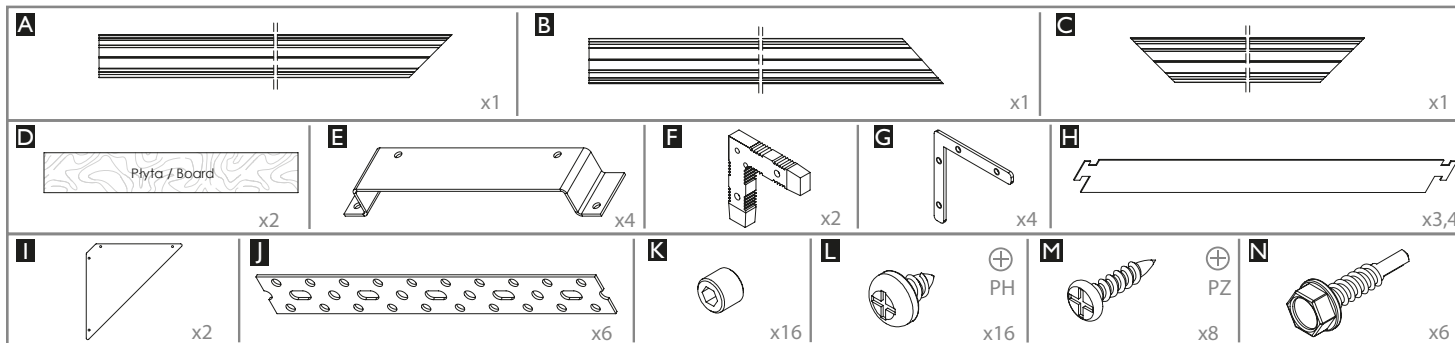
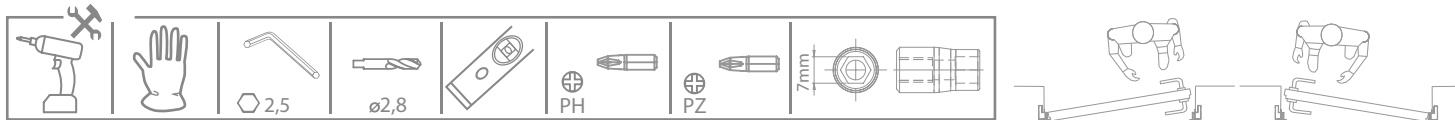

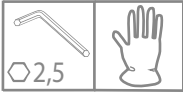

C, F, G, K

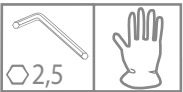
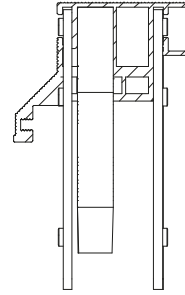
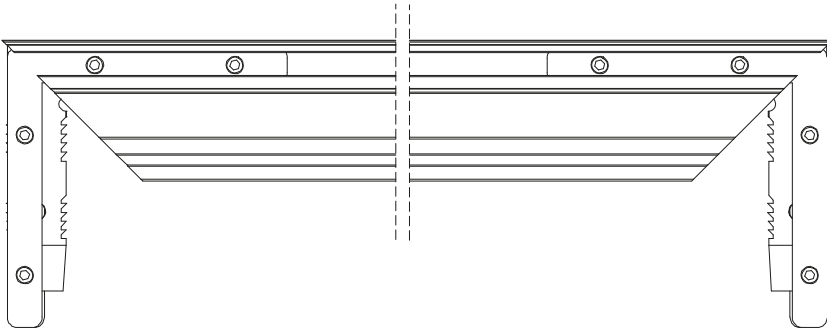
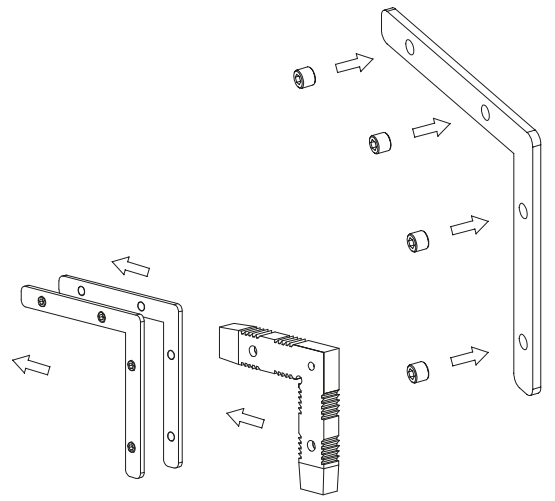
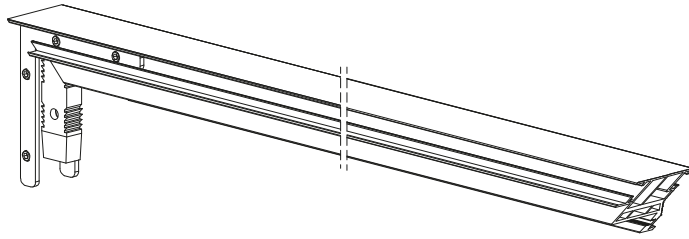

A, B

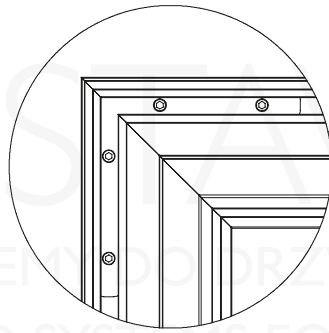
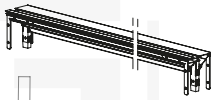

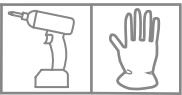

D, E, H, K, L

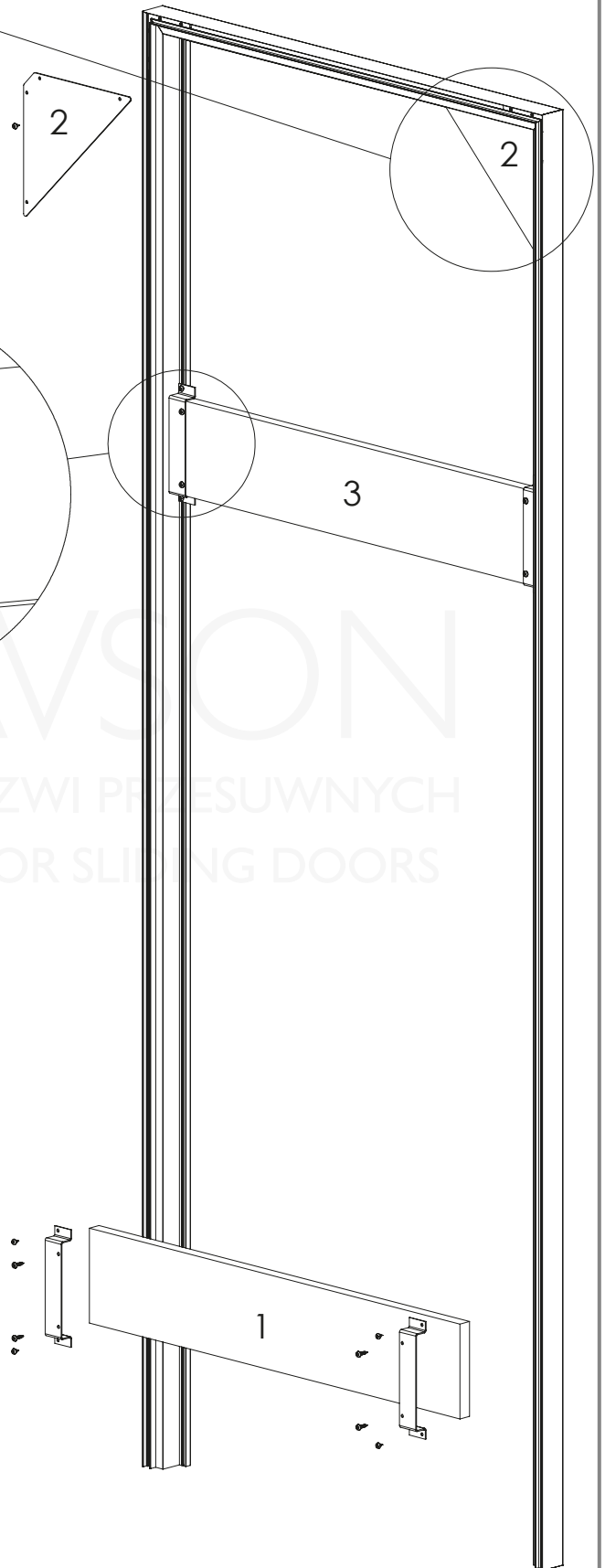
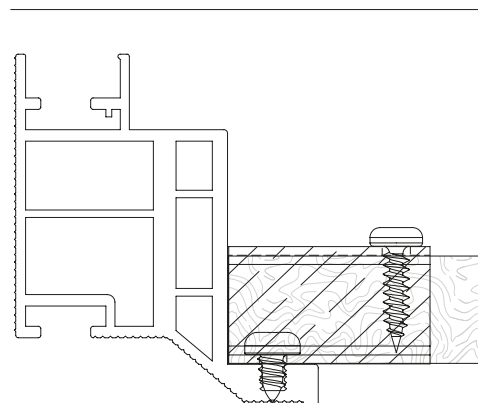
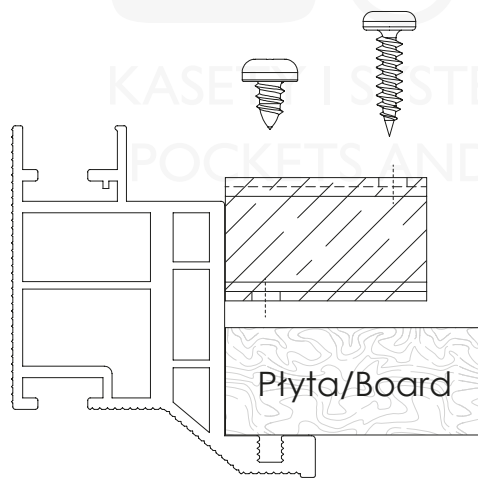
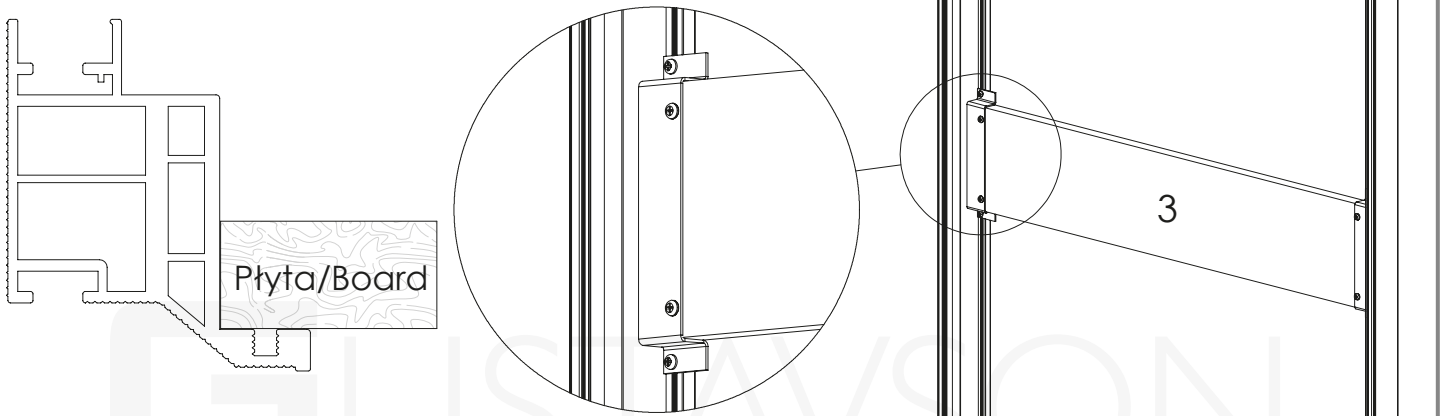
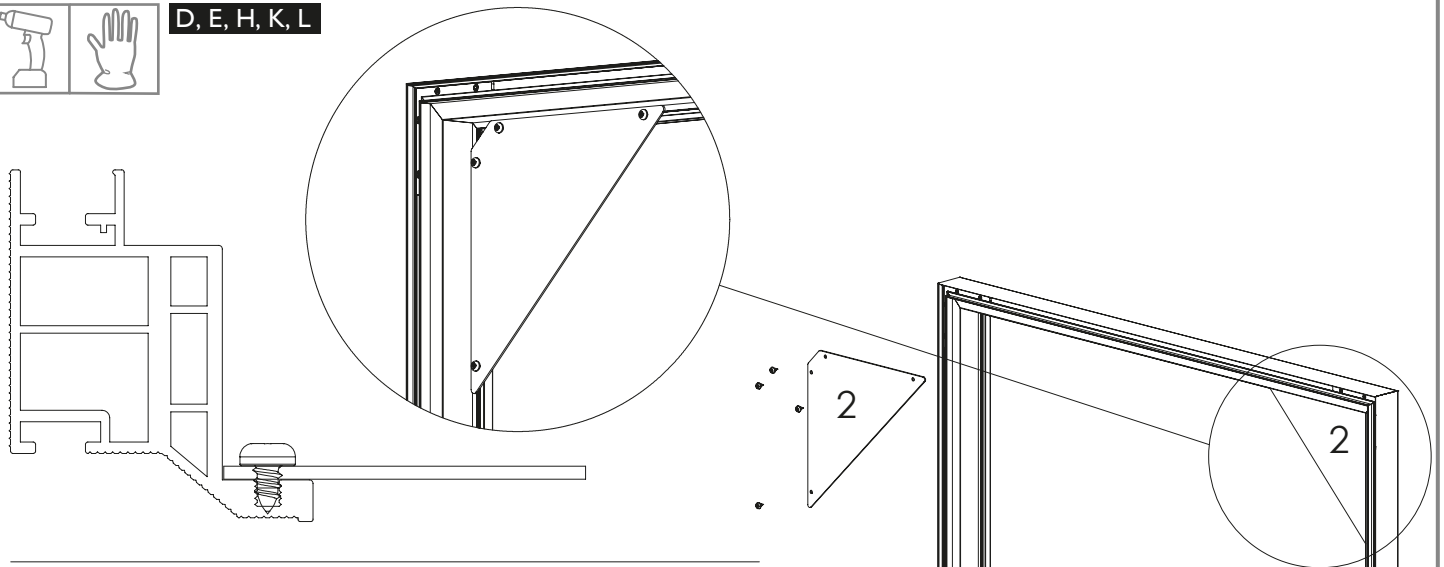

Montaż Ściana karton-gips

Montage Stud Wall

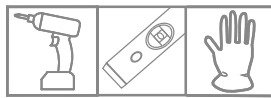

W przypadku różnego rodzaju podłóg zalecane jest użycie klinów w celu uniesienia ościeżnicy.
Use the wedges to lift the frame in the case of various types of floors.

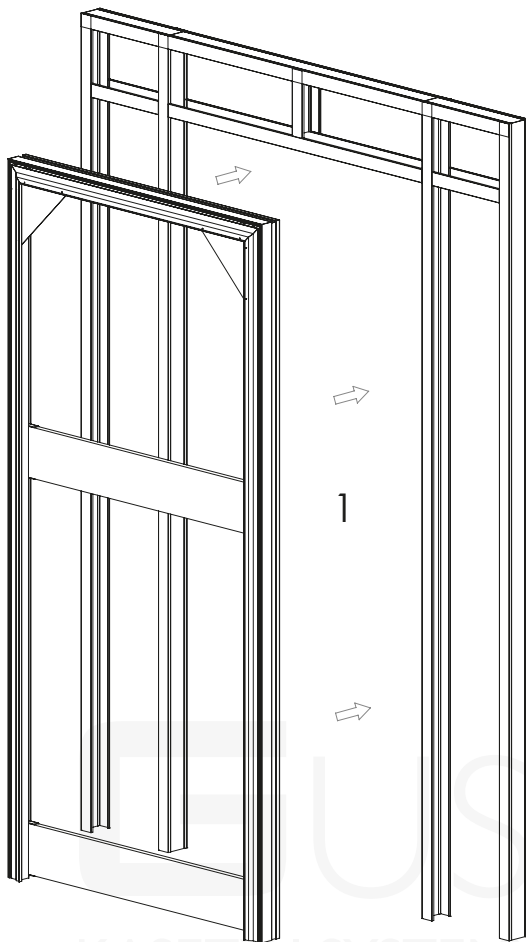
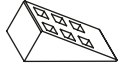

1

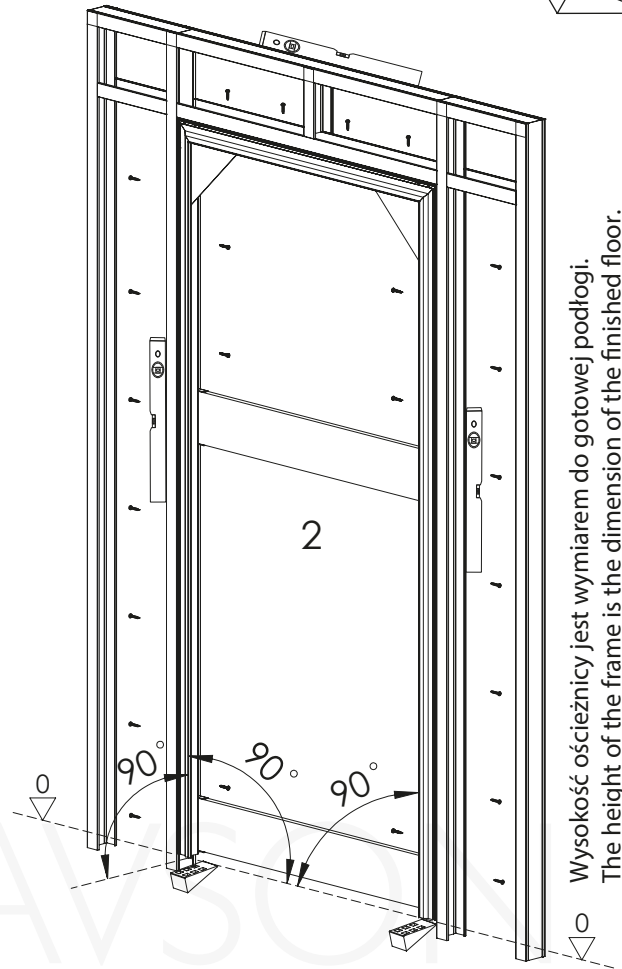

Wysokość ościeżnicy jest wymiarem do gotowej podłogi.
The height of the frame is the dimension of the finished floor.



KASETY I SYSTEMY DO DRZWI PRZESUWNYCH
POCKETS AND SYSTEMS FOR SLIDING DOORS

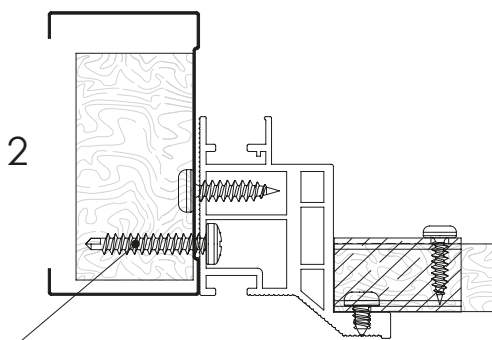

2

W otworach zawiasowch wkręcić dodatkowe wkręty dla wzmocnienia przy zawiasach.
In the hinge holes screw additional screws for reinforcement at the hinges.

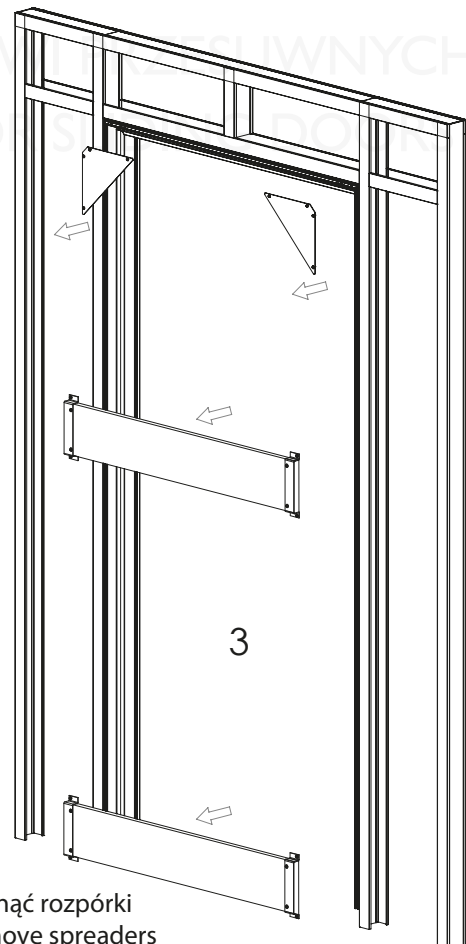

3

Usunąć rozpórki
Remove spreaders

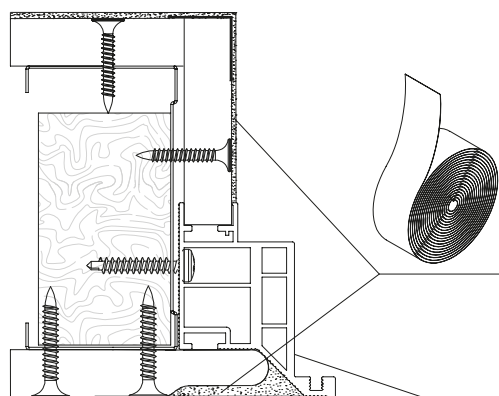
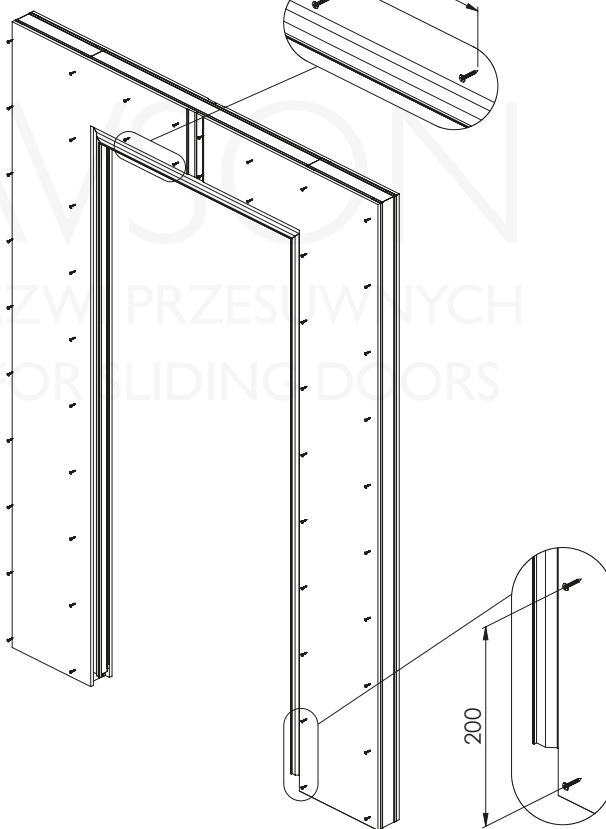
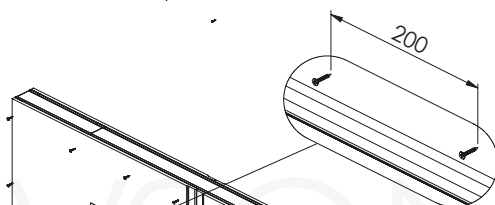
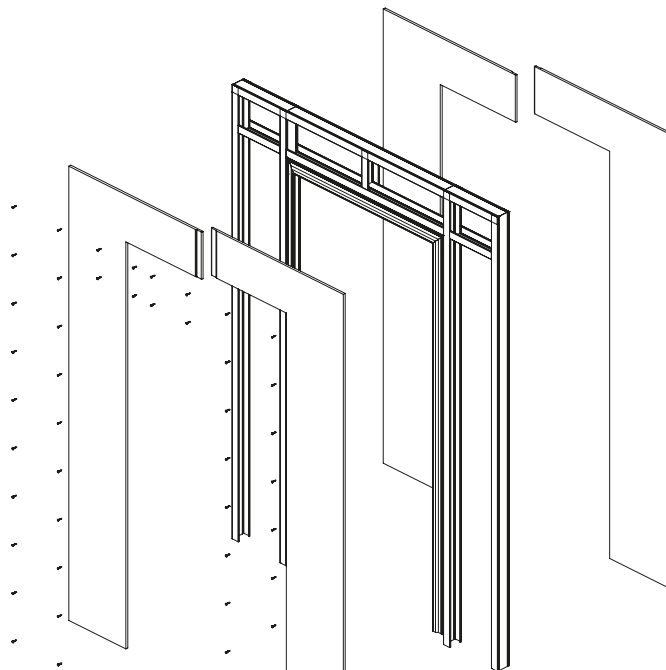
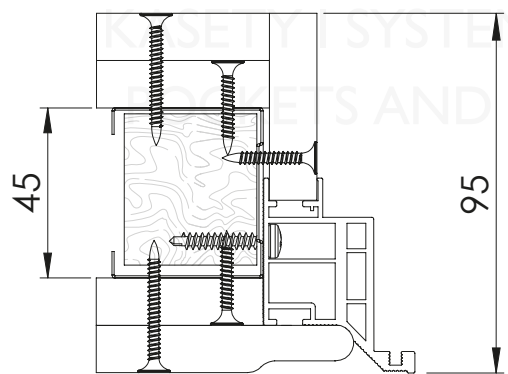
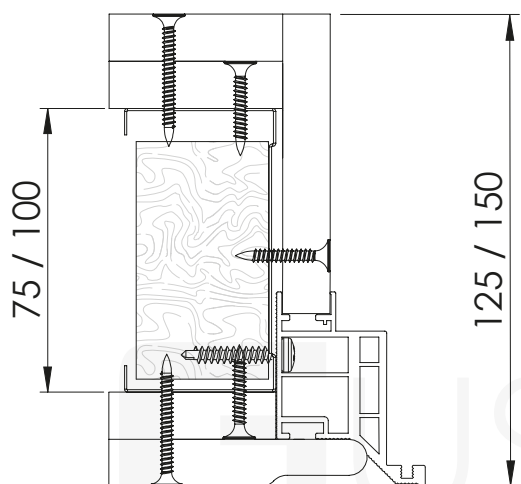
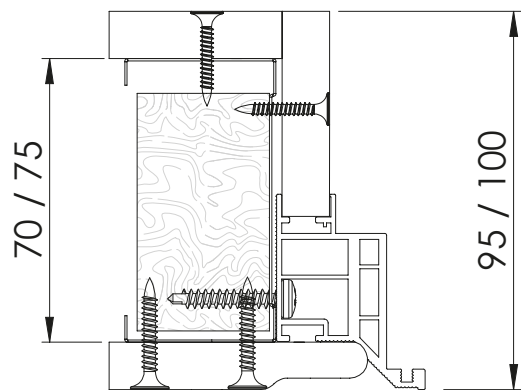
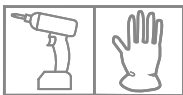

Szpachlować: Pierwsza warstwa, szpachel gruboziarnisty
Druga warstwa szpachel wykańczający
Przy szpachlowaniu użyć fizeliny lub siatki wzmacniającej na łączeniach.
Fill: First coat, coarse spatula, Second layer of finishing spatula
When skimming use a nonwoven or reinforcing mesh on all joints.

Usunąć folie ochronne z profili.
Profil można malować farbami ściennymi.
Remove the protective foil from the profiles.
The profiles can be painted with wall paint.

Montaż Ściana murowana
Montage Solid Wall



J, N

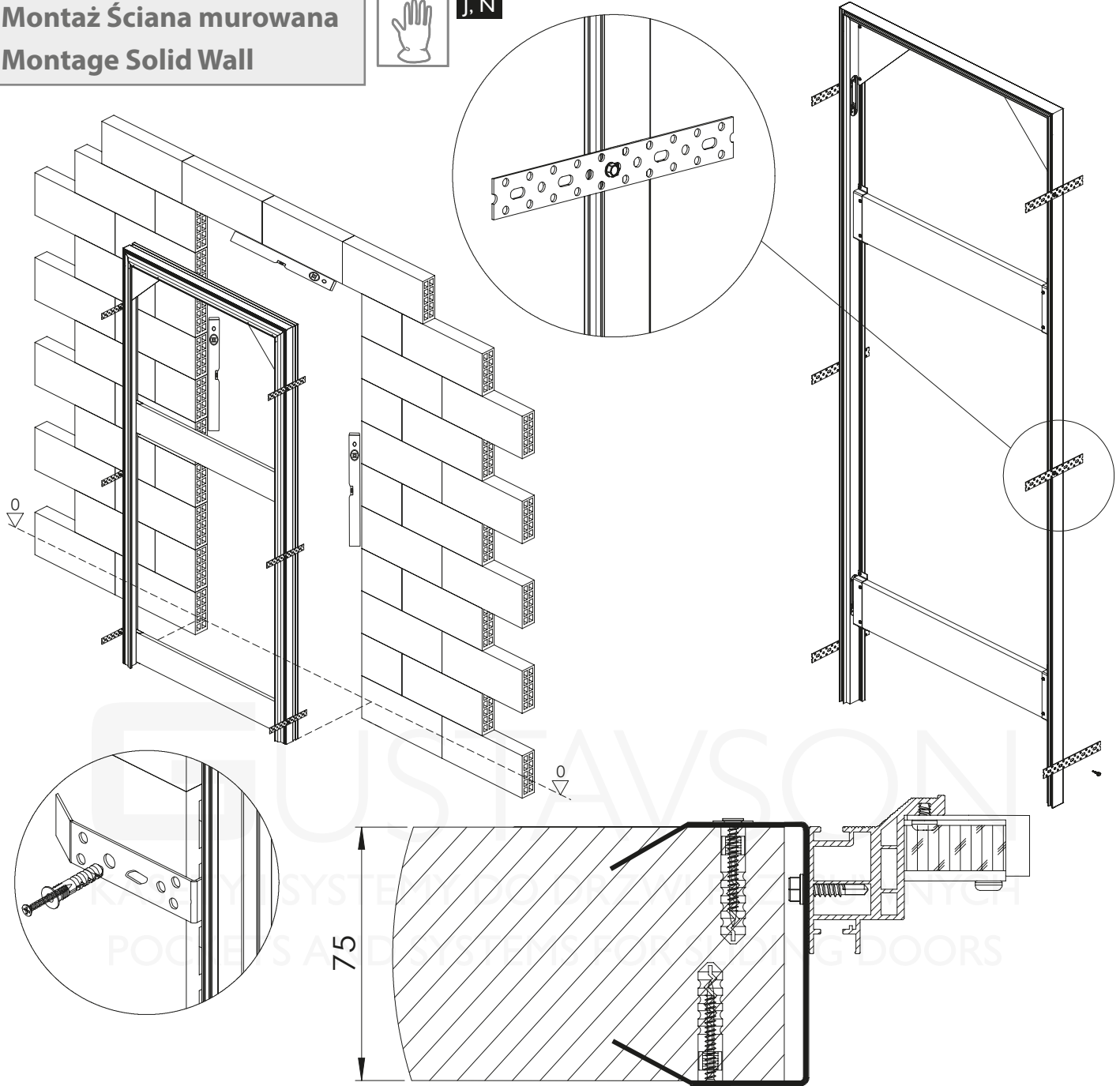

H

Zakleszczyć w profilu.
Pin in profile.

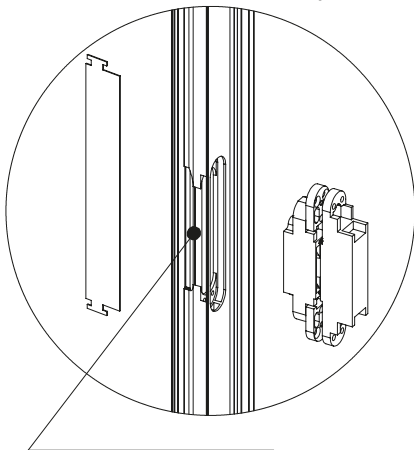

Miejsce pod zawiasy.
Place for Hinges.

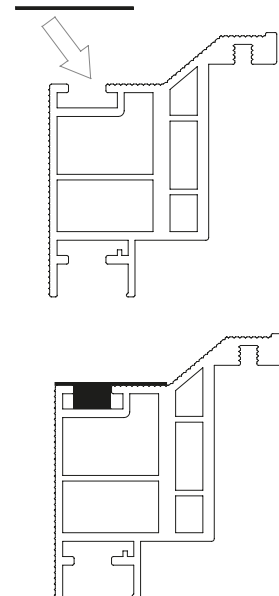
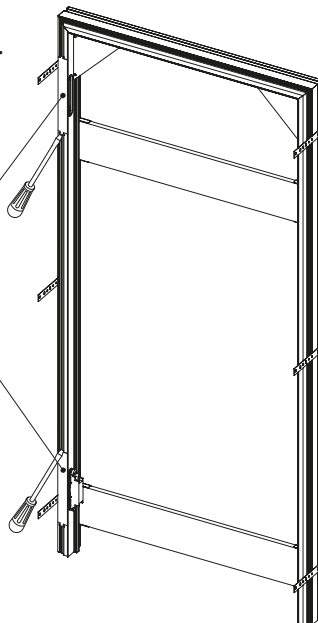

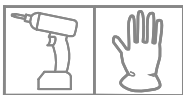

W przypadku różnego rodzaju podłóg zalecane jest użycie klinów w celu uniesienia ościeżnicy.
Use the wedges to lift the frame in the case of various types of floors.

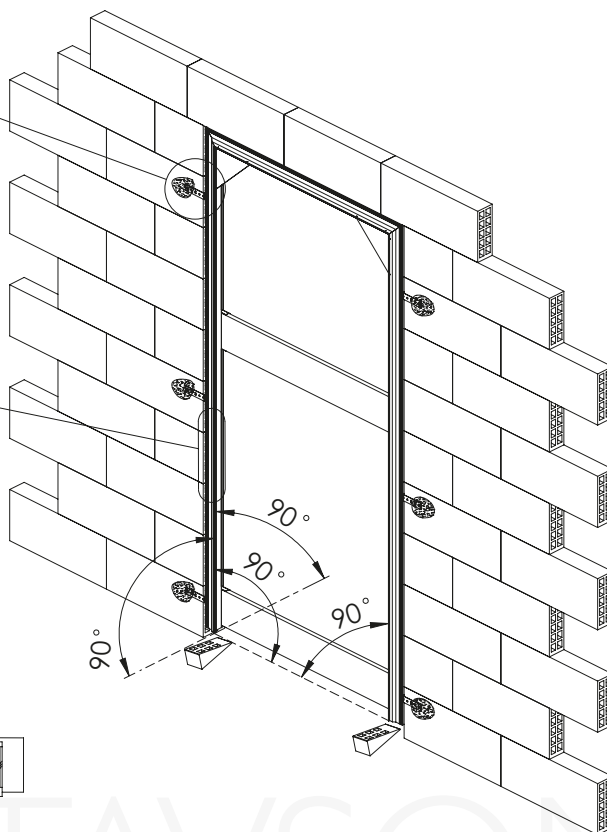
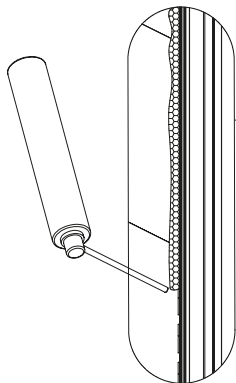
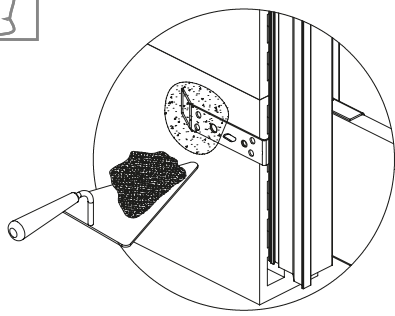
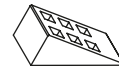

Wysokość ościeżnicy jest wymiarem do gotowej podłogi.
The height of the frame is the dimension of the finished floor.

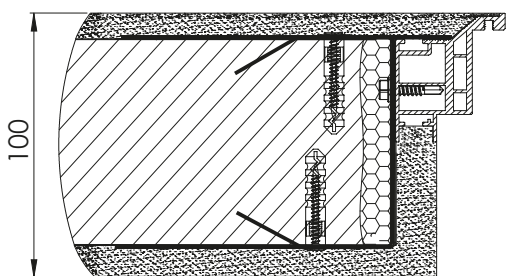
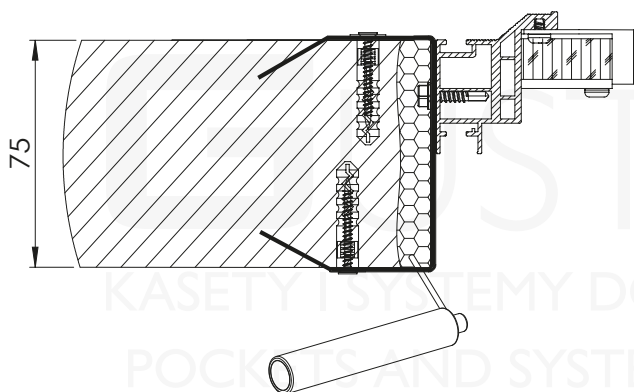

Przy tynkowaniu użyć siatki wzmacniającej na łączeniach.
When using plastering, use reinforcing mesh on the joints.

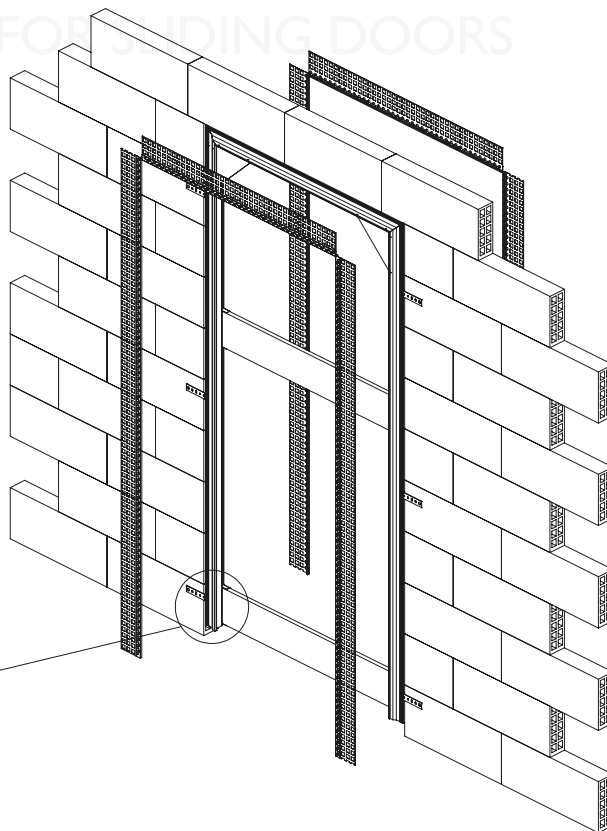
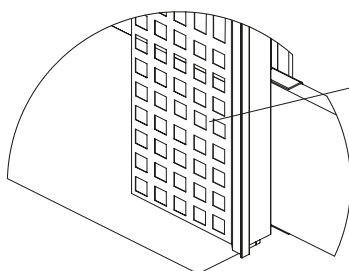
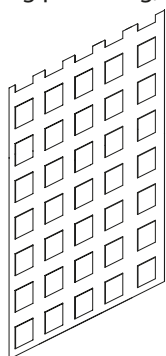

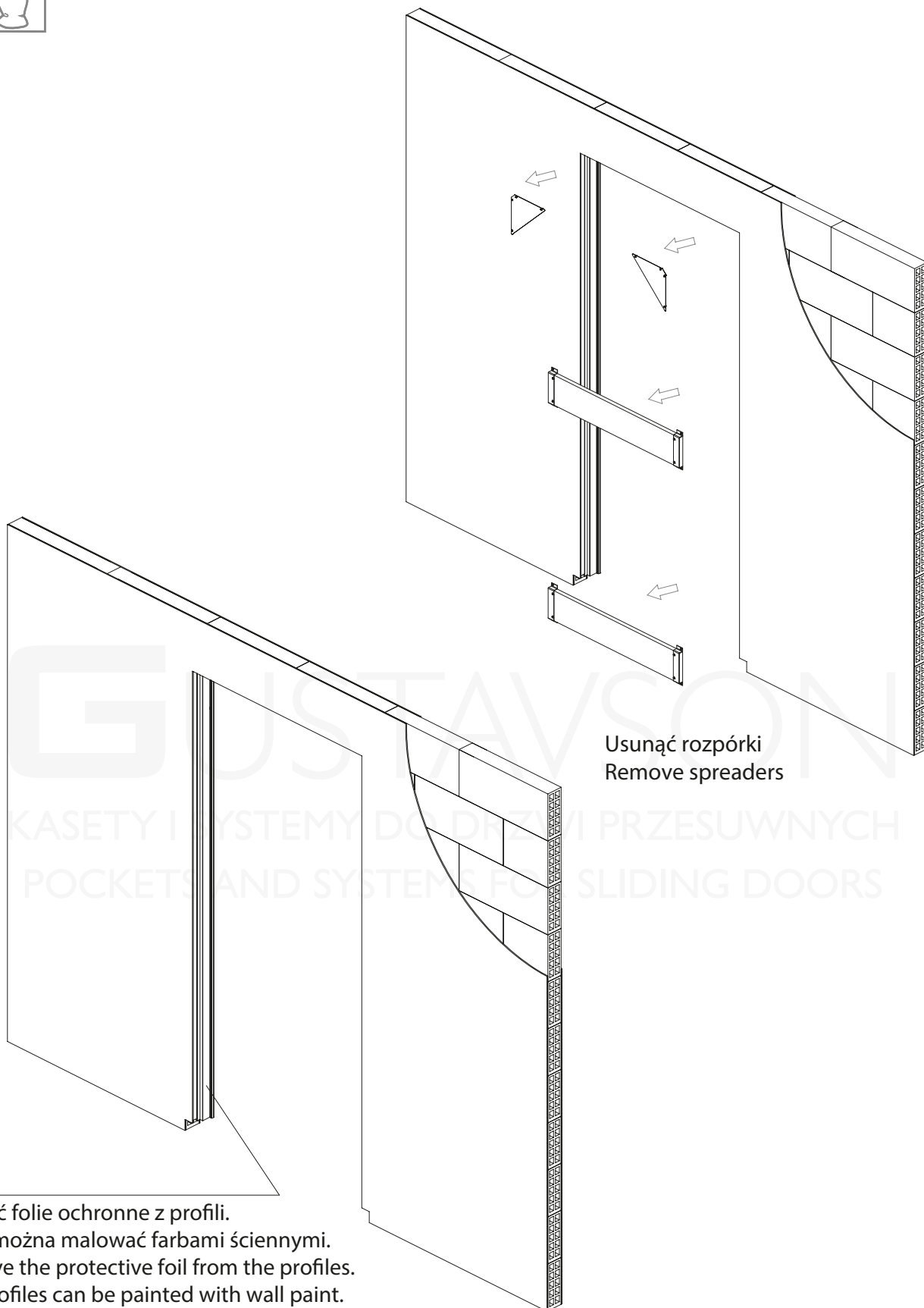
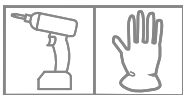

Usunąć rozpórki
Remove spacers

Usunąć folie ochronne z profili.
Profil można malować farbami ściennymi.
Remove the protective foil from the profiles.
The profiles can be painted with wall paint.

Zaleca się postępowanie zgodnie z niniejszą instrukcją przy użyciu odpowiednich narzędzi, zgodnych ze wskazaniami. W przypadku elementów, których powierzchnia może być ostra należy stosować środki ochrony indywidualnej oraz zabezpieczenie obszaru pracy. Firma Laguna Fabryka Okuć Sp. z o.o. Sp. k. uchyła się od odpowiedzialności za działania wynikające z postępowania niezgodnego z niniejszą instrukcją.

It is recommended that you follow these instructions using the appropriate tools as indicated. In the case of elements whose surface can be sharp, use personal protective equipment and work area protection. The company Laguna Hardware Factory Limited Liability Limited Partnership, refrains from liability for actions resulting from conduct incompatible with this instruction.