

# Visio 40 wewnętrzny z belką

100  
kg

MONTAŻ DO  
GOTOWEJ PODŁOGI  
MOUNTING ON FINISHED  
FLOOR LEVEL

40 mm  
PŁYTA | BOARD

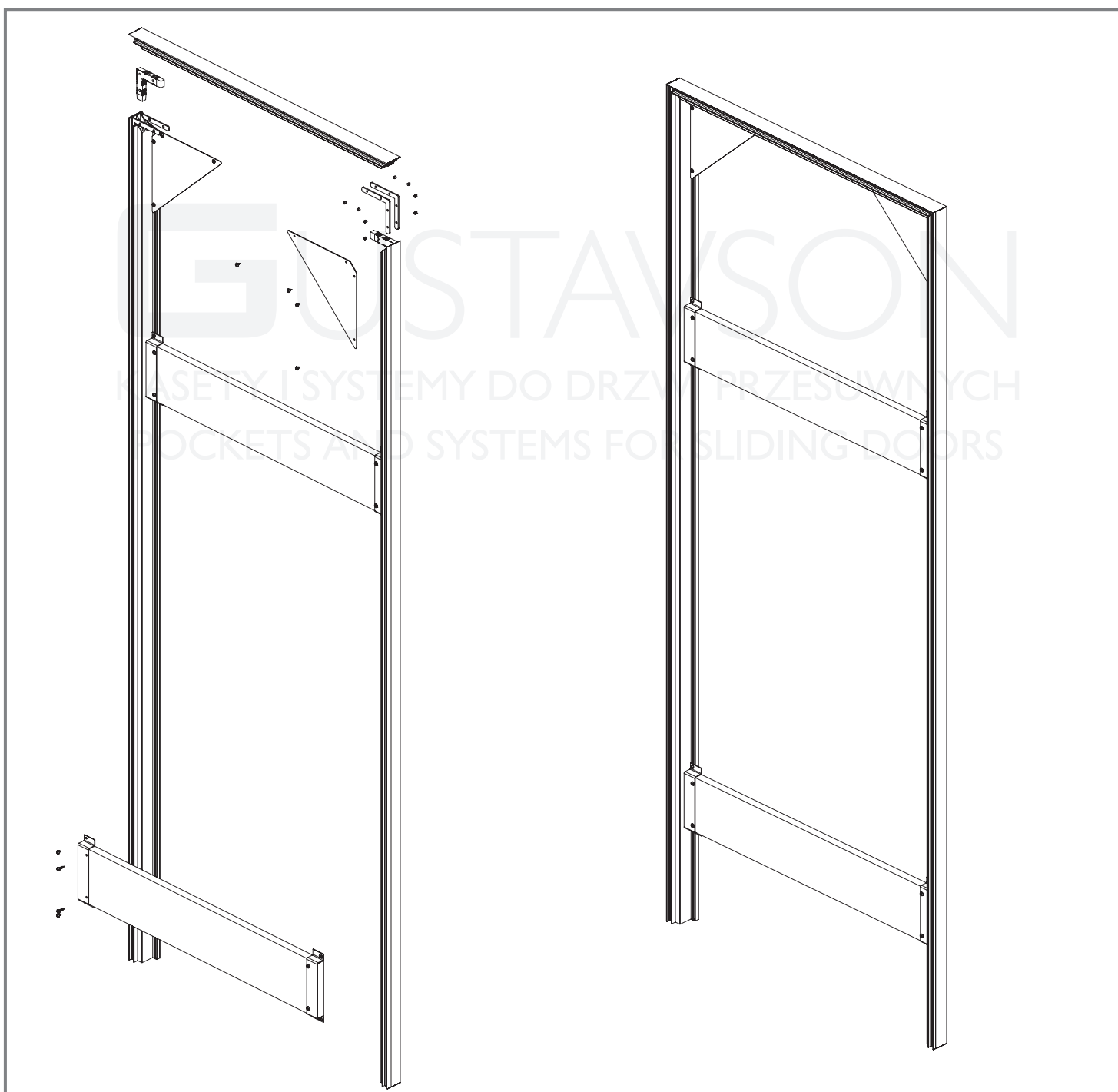
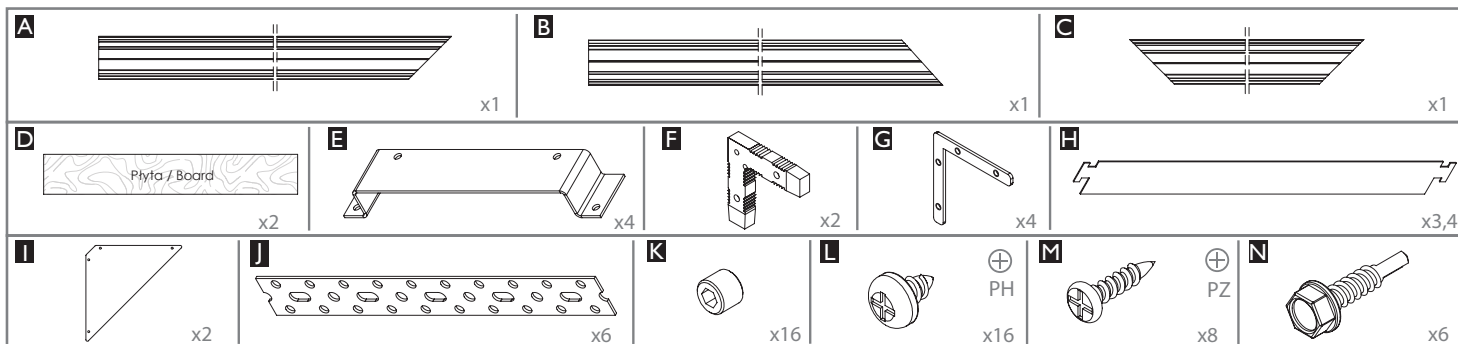
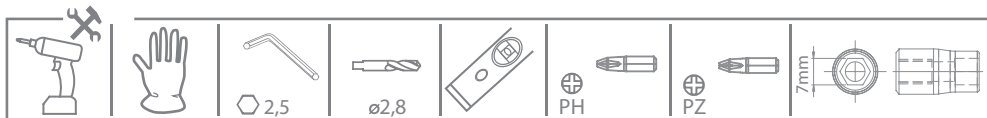

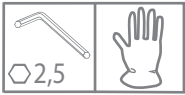

C, F, G, K

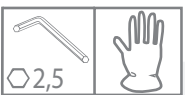
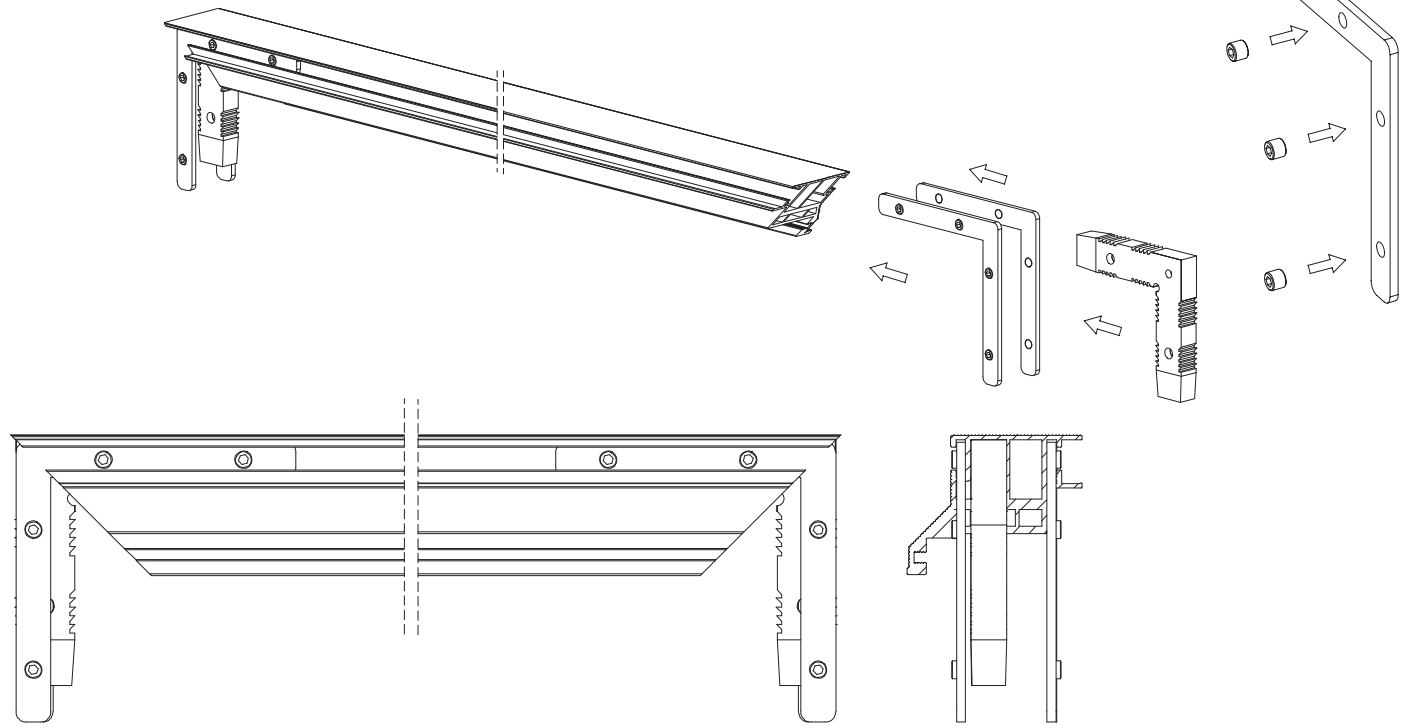

A, B

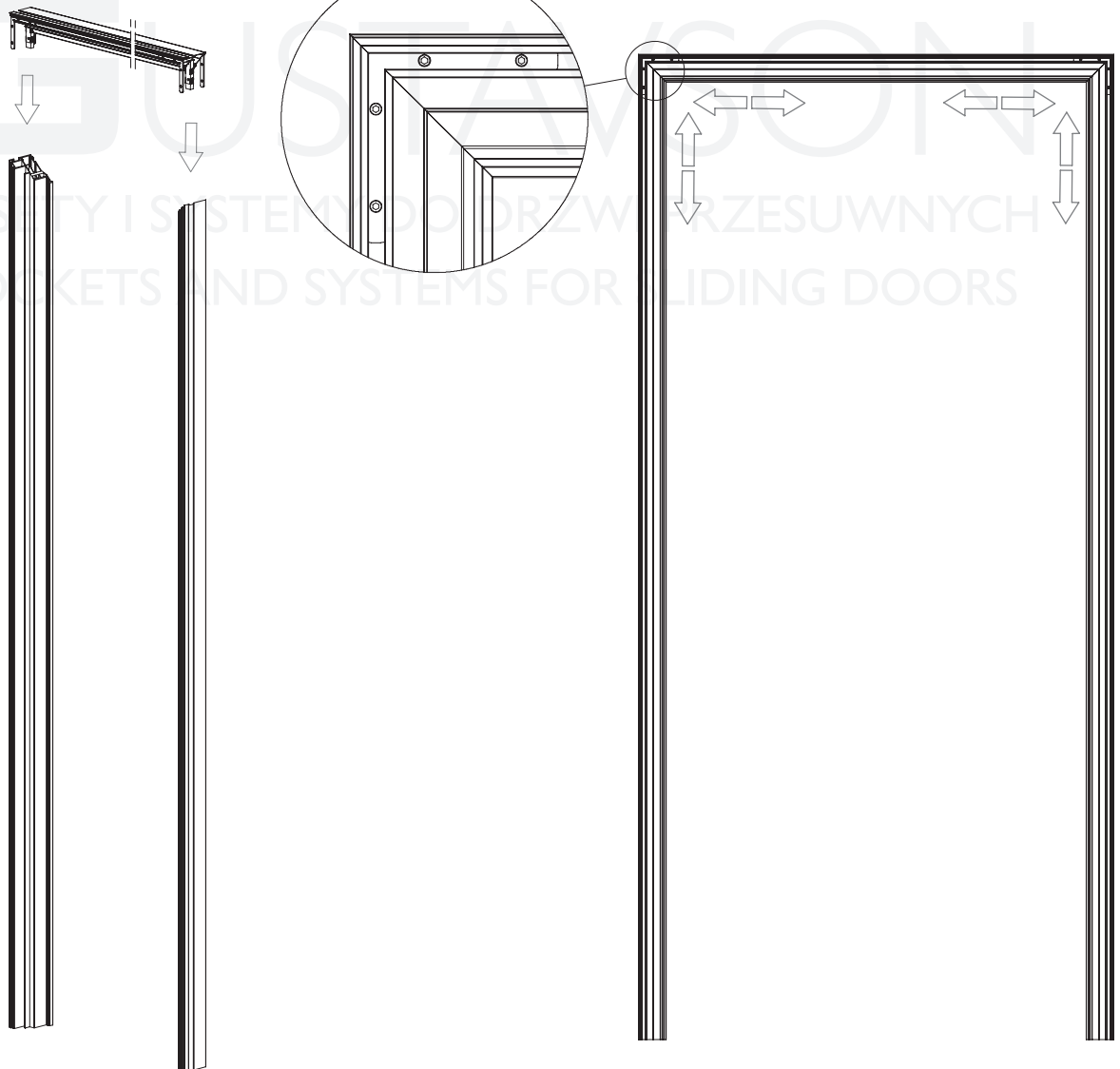



D, E, H, K, L

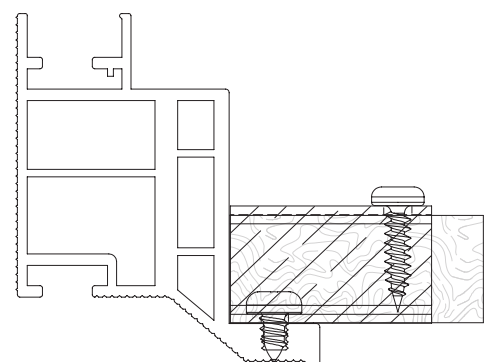
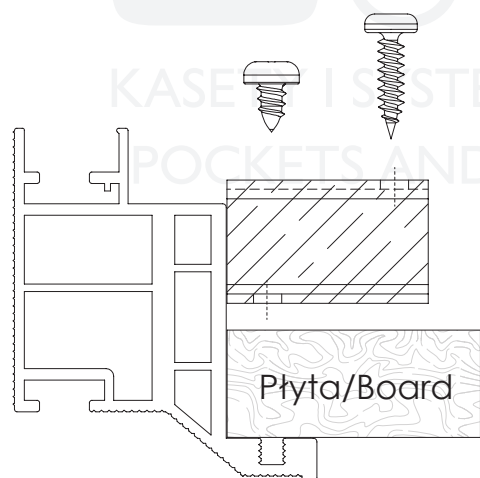
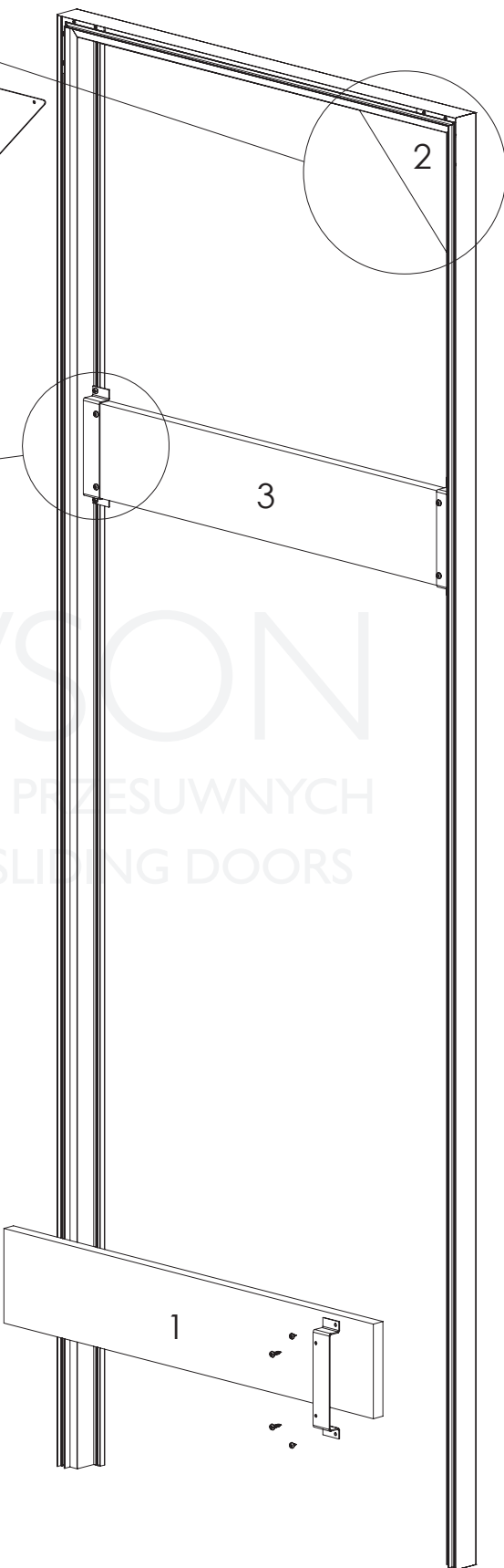
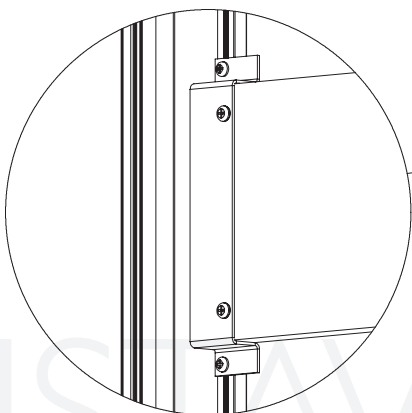
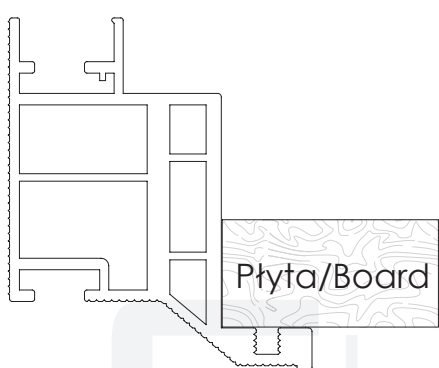
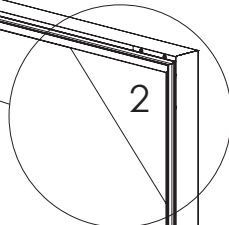
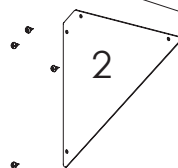
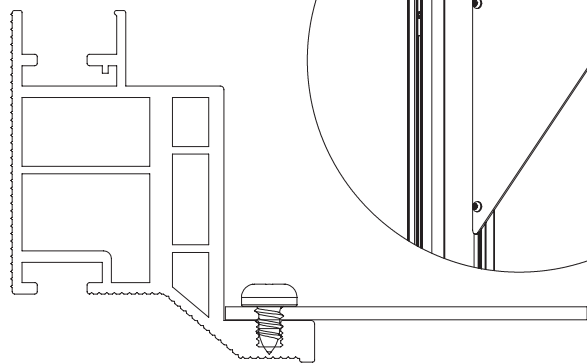
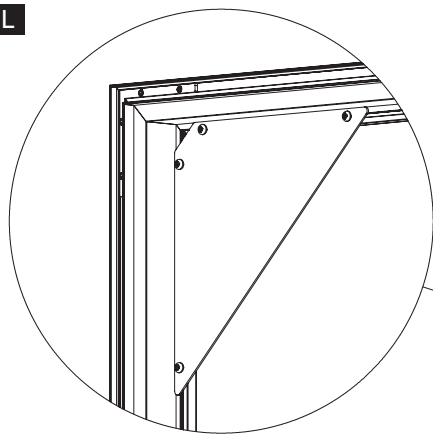

## Montaż Ściana karton-gips Montage Stud Wall

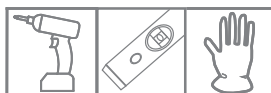

W przypadku różnego rodzaju podłóg zalecane jest użycie klinów w celu uniesienia ościeżnicy.  
Use the wedges to lift the frame in the case of various types of floors.

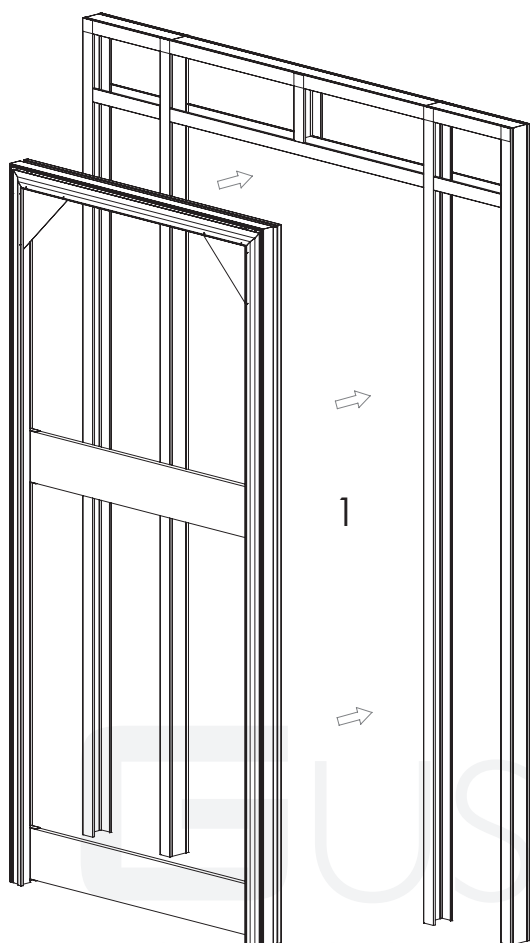
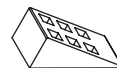

1

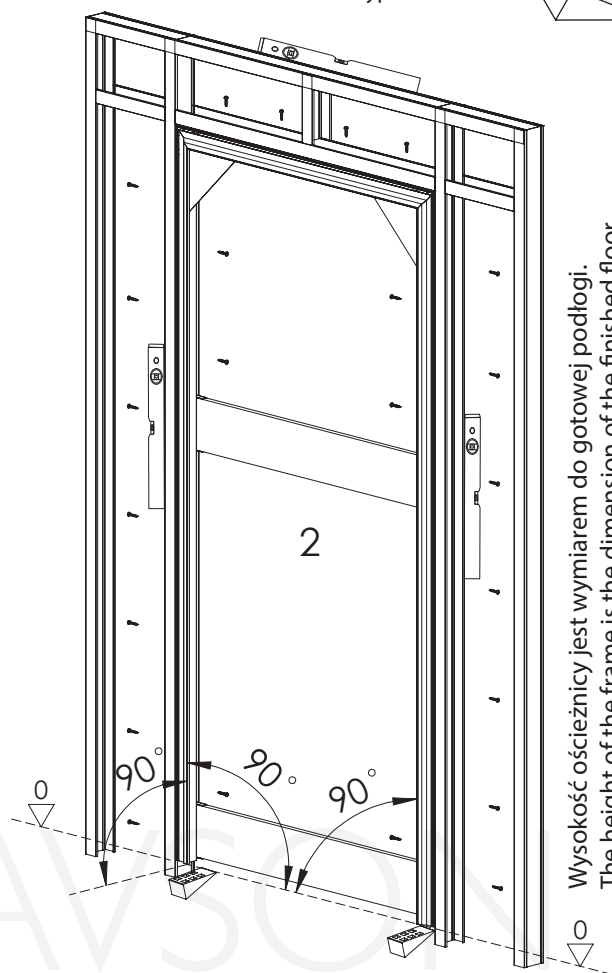

Wysokość ościeżnicy jest wymiarem do gotowej podłogi.  
The height of the frame is the dimension of the finished floor.

KASETY I SYSTEMY DO DRZWI PRZESUWNYCH  
POCKETS AND SYSTEMS FOR SLIDING DOORS

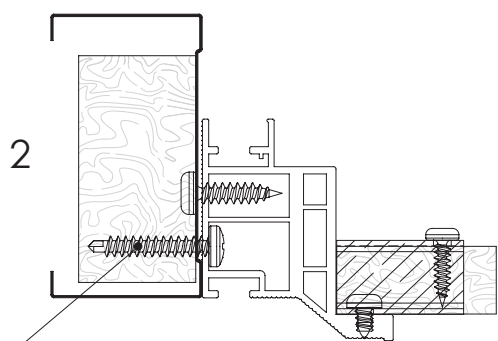

2

W otworach zawiasowch wkręcić dodatkowe wkręty dla wzmocnienia przy zawiasach.  
In the hinge holes screw additional screws for reinforcement at the hinges.

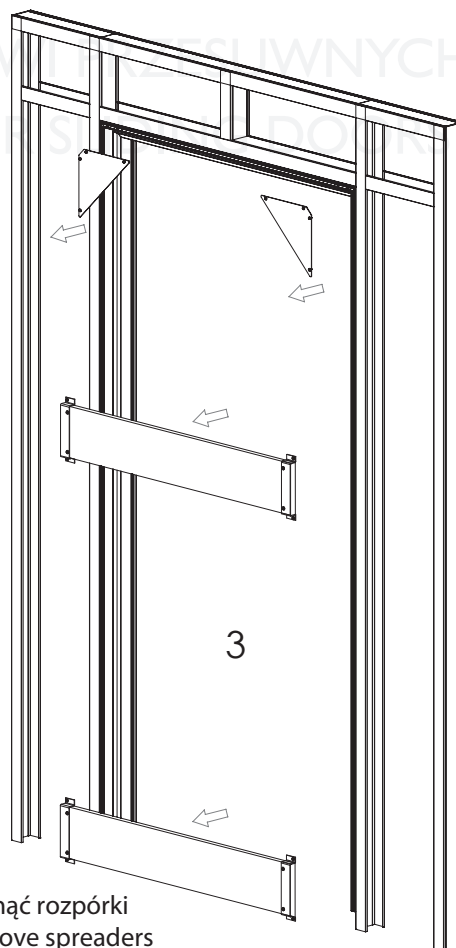

3

Usunąć rozpórki  
Remove spreaders

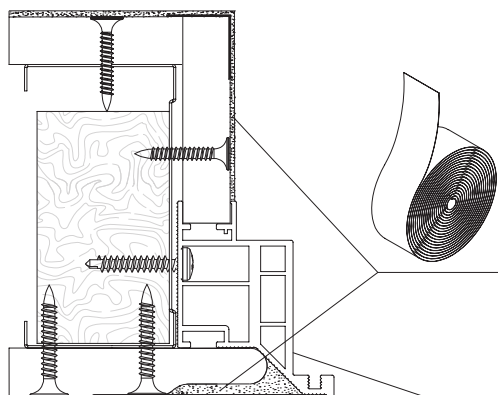
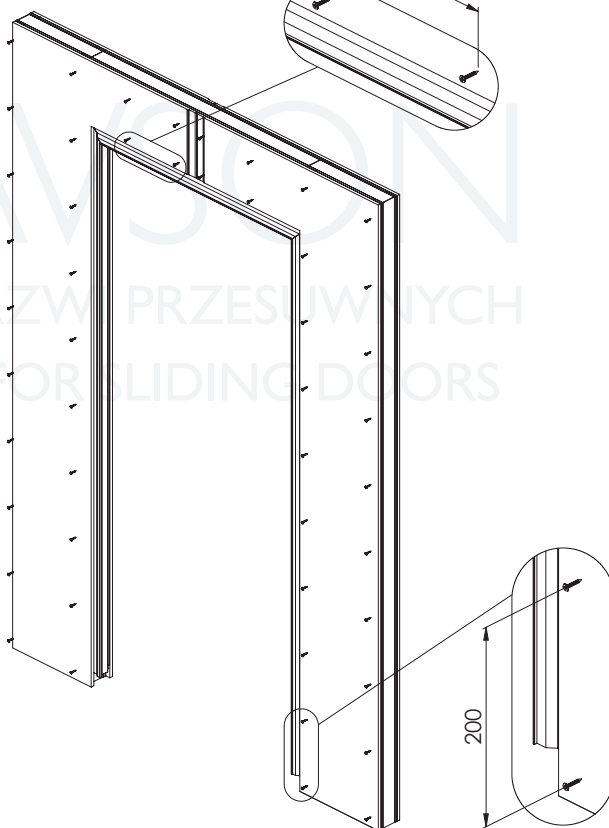
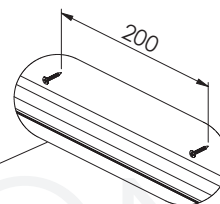
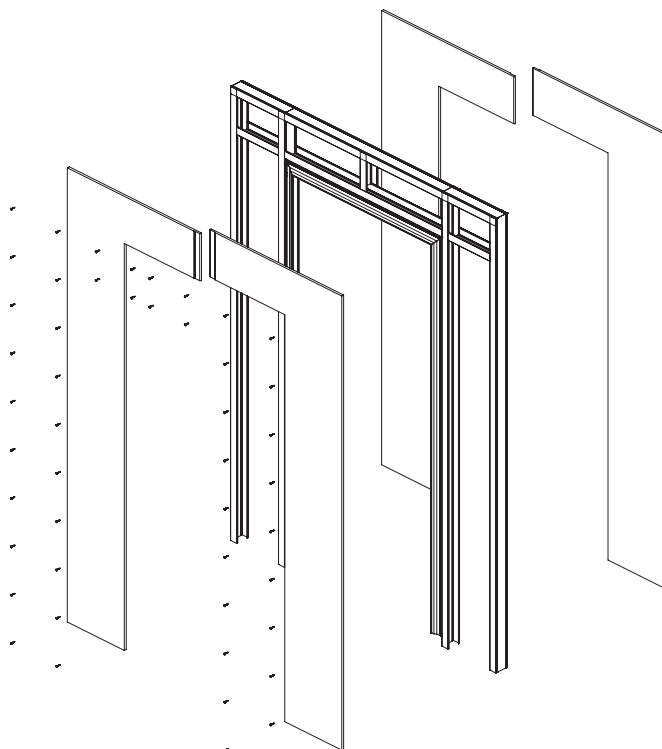
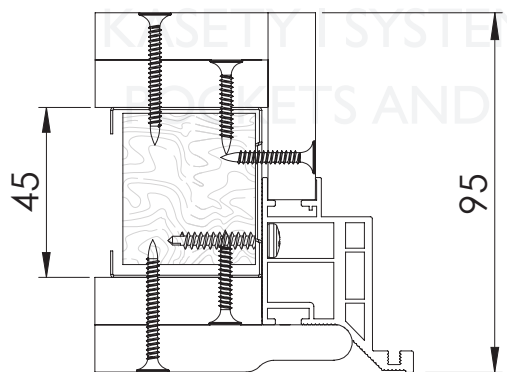
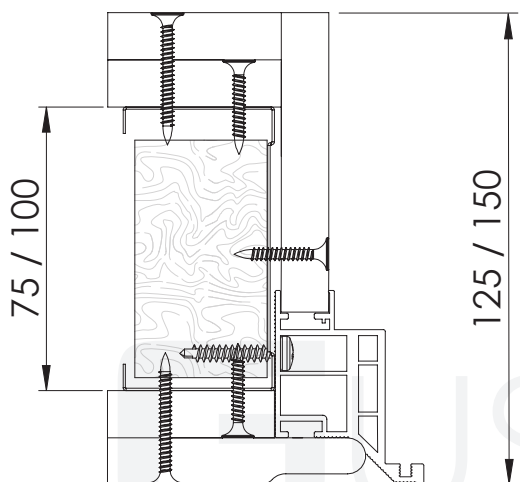
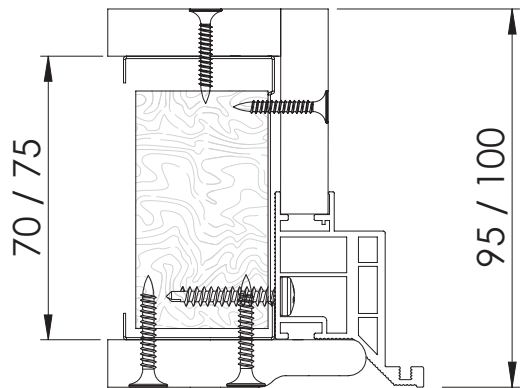

Szpachlować: Pierwsza warstwa, szpachel gruboziarnisty  
 Druga warstwa szpachel wykańczający  
 Przy szpachlowaniu użyć fizeliny lub siatki wzmacniającej na łączeniach.  
 Fill: First coat, coarse spatula, Second layer of finishing spatula  
 When skimming use a nonwoven or reinforcing mesh on all joints.

Usunąć folie ochronne z profili.  
 Profil można malować farbami ściennymi.  
 Remove the protective foil from the profiles.  
 The profiles can be painted with wall paint.

**Montaż Ściana murowana**  
**Montage Solid Wall**



J, N

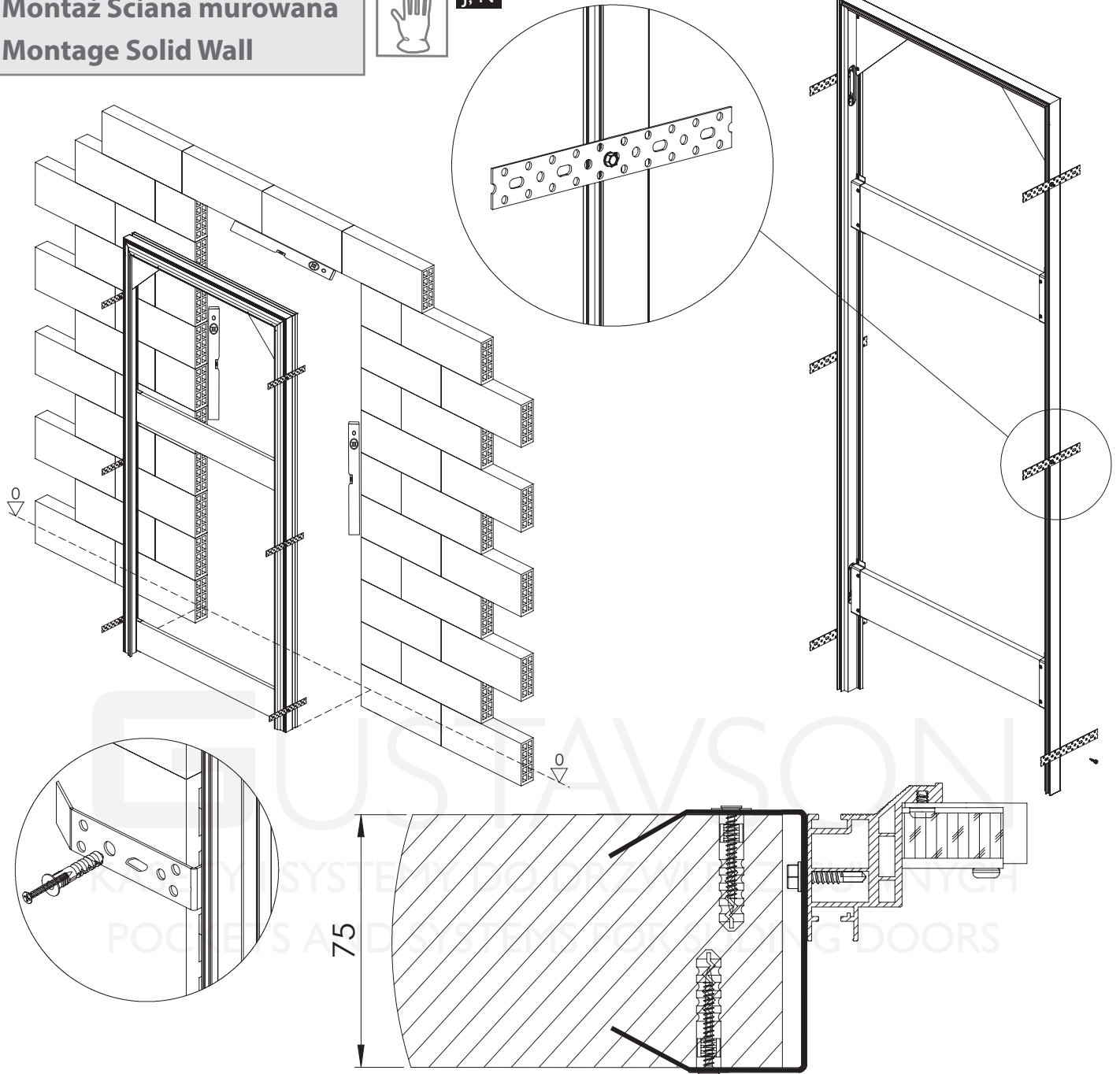

H

Zakleszczyć w profilu.  
 Pin in profile.

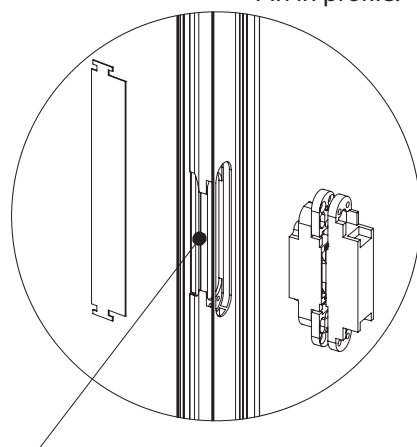

Miejsce pod zawiasy.  
 Place for Hinges.

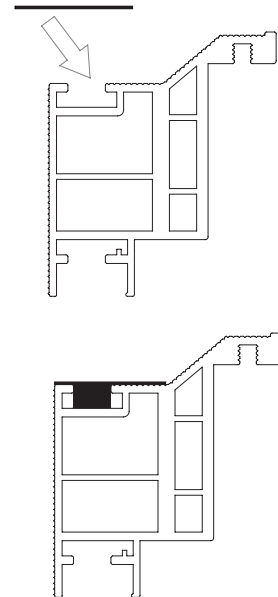
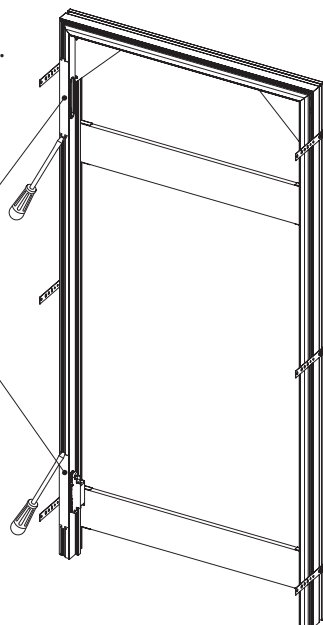



W przypadku różnego rodzaju podłóg zalecane jest użycie klinów w celu uniesienia ościeżnicy.  
Use the wedges to lift the frame in the case of various types of floors.

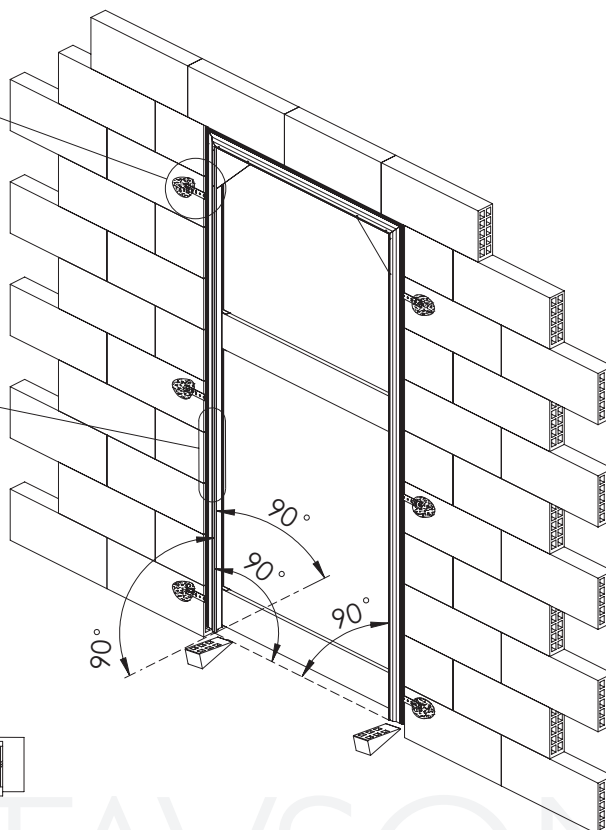
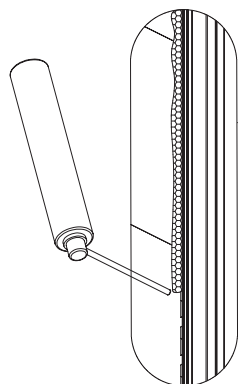
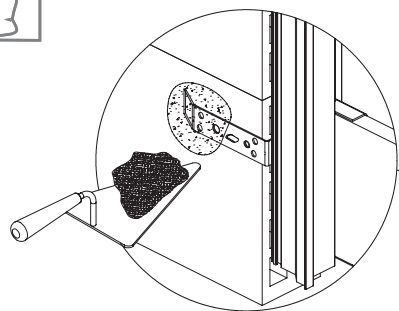
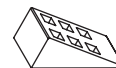

Wysokość ościeżnicy jest wymiarem do gotowej podłogi.  
The height of the frame is the dimension of the finished floor.

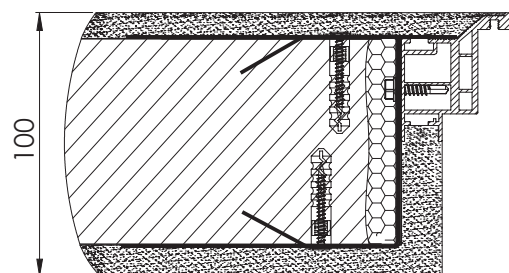
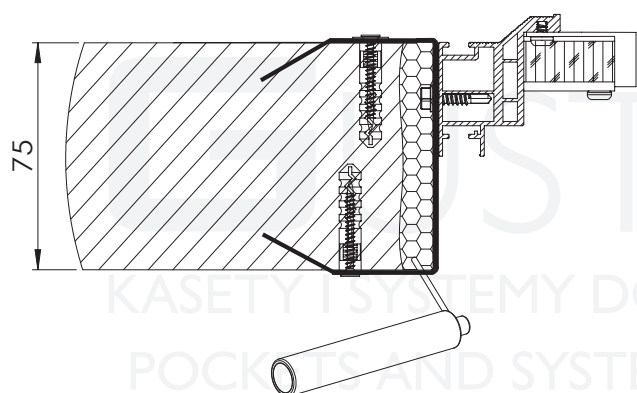

Przy tynkowaniu użyć siatki wzmacniającej na łączeniach.  
When using plastering, use reinforcing mesh on the joints.

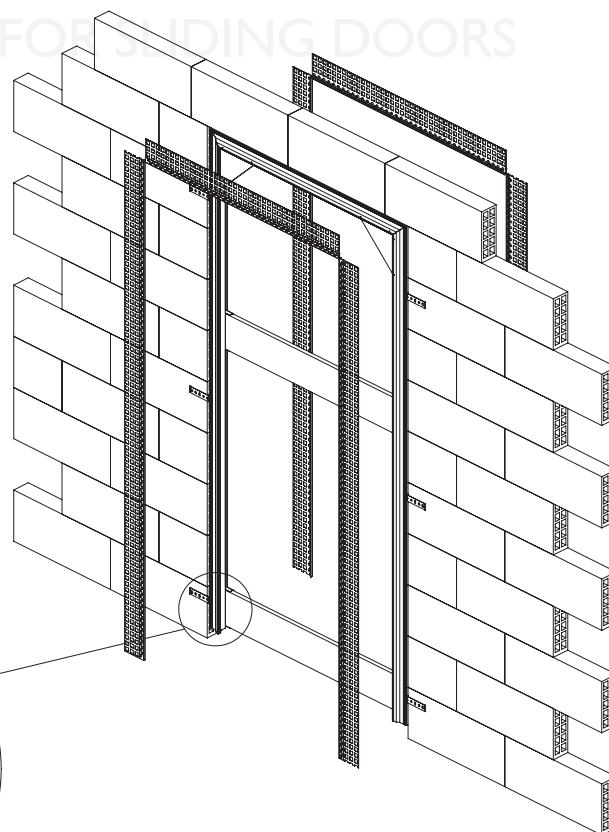
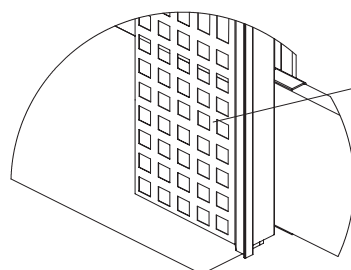
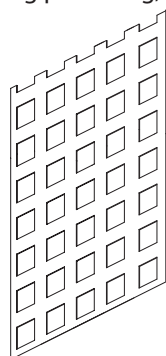

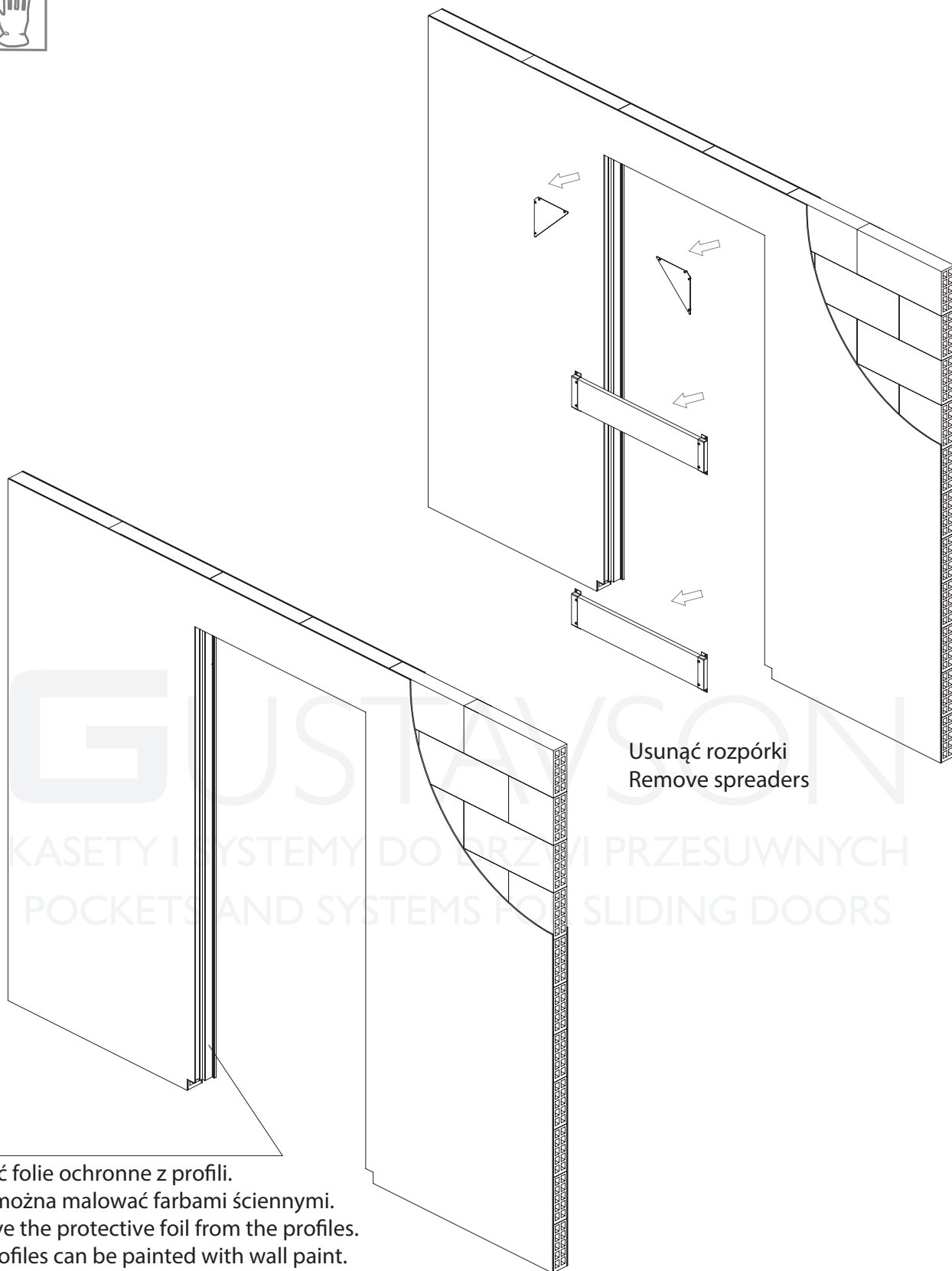

Usunąć rozpórki  
Remove spreaders

Usunąć folie ochronne z profili.  
Profil można malować farbami ściennymi.  
Remove the protective foil from the profiles.  
The profiles can be painted with wall paint.

Zarysowania produktu na białej powierzchni, pokrytej powłoką farby podkładowej nie wpływają na istotne cechy użytkowe produktu - nie stanowią podstawy do reklamacji ani nie są objęte gwarancją producenta. Warstwa powłoki podkładowej służy do pokrycia docelową powłoką malarską lub innym docelowym materiałem wykończeniowym wybranym przez klienta.

Scratches on a white surface covered with a primer paint do not affect the product's essential functionalities - they are not a basis for a complaint and are not covered by the manufacturer's warranty. The undercoat layer is used to cover with the target paint coat or other target finish material chosen by the customer.

Zaleca się postępowanie zgodnie z niniejszą instrukcją przy użyciu odpowiednich narzędzi, zgodnych ze wskazaniami. W przypadku elementów, których powierzchnia może być ostra należy stosować środki ochrony indywidualnej oraz zabezpieczenie obszaru pracy. Firma Laguna Fabryka Okuć Sp. z o.o. Sp. k. uchyla się od odpowiedzialności za działania wynikające z postępowania niezgodnego z niniejszą instrukcją.

If it is recommended that you follow these instructions using the appropriate tools as indicated. In the case of elements whose surface can be sharp, use personal protective equipment and work area protection. The company Laguna Hardware Factory Limited Liability Limited Partnership refrains from liability for actions resulting from conduct incompatible with this instruction.